

Computational Modeling of Doubly Fed Induction Generator Wind Turbine Technology

¹Rushikesh V. Pandya, ²Prof. (Dr.) Sandipkumar R. Panchal, ³Prof. (Dr.) Nilay N. Shah

^{1,2}*Dr. Subhash University, Junagadh 362001, Gujarat, India*

³*Sardar Vallabhbhai Patel Institute of Technology, Vasad 388306, Gujarat, India*

Abstract: The present research work deals with the control of grid frequency by controlling the operation of doubly fed induction generator and also control regulation of active power of demand and supplied by grid with help of doubly fed induction generator. The evolution of technology related to wind systems industry led to the development of a generation of variable speed wind turbines that present many advantages compared to the fixed speed wind turbines. These wind energy conversion systems are connected to the grid through Voltage Source Converters (VSC) to make variable speed operation possible. The studied system here is a variable speed wind generation system based on Doubly Fed Induction Generator (DFIG). The rotor side converter (RSC) usually provides active and reactive power control of the machine while the grid-side converter (GSC) keeps the voltage of the DC-link constant. The additional freedom of reactive power generation by the GSC is usually not used due to the fact that it is more preferable to do so using the RSC. This paper deals with the introduction of doubly fed induction generator, AC/DC/AC converter control and finally the SIMULINK/MATLAB simulation for isolated Induction generator as well as for grid connected Doubly Fed Induction Generator and corresponding results and wave forms are displayed.

Index Terms -DFIG, Rotor Side Converter, Grid Side Converter, Converter Control Diagram, Simulink Diagram, Wind Turbine Modeling, Wind Energy.

I. INTRODUCTION

Nowadays the demand of electrical energy is increasing day by day but the presence of coal, fossils fuels are towards the end. So it is very much required to find another way to generate the electricity. Wind energy is a non-conventional source of energy and often installed in remote, rural areas which areas usually have weak grids, often with voltage unbalances and under voltage conditions. Wind

energy has been the subject of much recent research and development. With increased penetration of wind power into electrical grids, DFIG wind turbines are largely deployed due to their variable speed feature and hence influencing system dynamics. This has created an interest in developing suitable models for DFIG to be integrated into power system studies. The continuous trend of having high penetration of wind power, in recent years, has made it necessary to introduce new practices. For example, grid codes are being revised to ensure that wind turbines would contribute to the control of voltage and frequency and also to stay connected to the host network following a disturbance. Renewable energy sources not contributing to the enhanced greenhouse effect, especially wind power, are becoming an important component of the total generation. Hence, research concerning the dynamic behavior of wind energy systems is important to achieve a better knowledge. In response to the new grid code requirements, several DFIG models have been suggested recently, including the full-model which is a 5th order model. These models use quadrature and direct components of rotor voltage in an appropriate reference frame to provide fast regulation of voltage.

II. DOUBLY FED INDUCTION GENERATOR

Wind turbines use a doubly-fed induction generator (DFIG) consisting of a wound rotor induction generator and an AC/DC/AC IGBT-based PWM converter. The stator winding is connected directly to the 50 Hz grid while the rotor is fed at variable frequency through the AC/DC/AC converter. The DFIG technology allows extracting maximum energy from the wind for low wind speeds by optimizing the turbine speed, while minimizing mechanical stresses on the turbine during gusts of wind. The optimum turbine speed producing maximum mechanical energy for a given wind speed is proportional to the wind speed. Another advantage of the DFIG technology is the ability for power electronic converters to generate or absorb reactive power, thus eliminating the need for installing capacitor banks as in the case of squirrel-cage induction generator

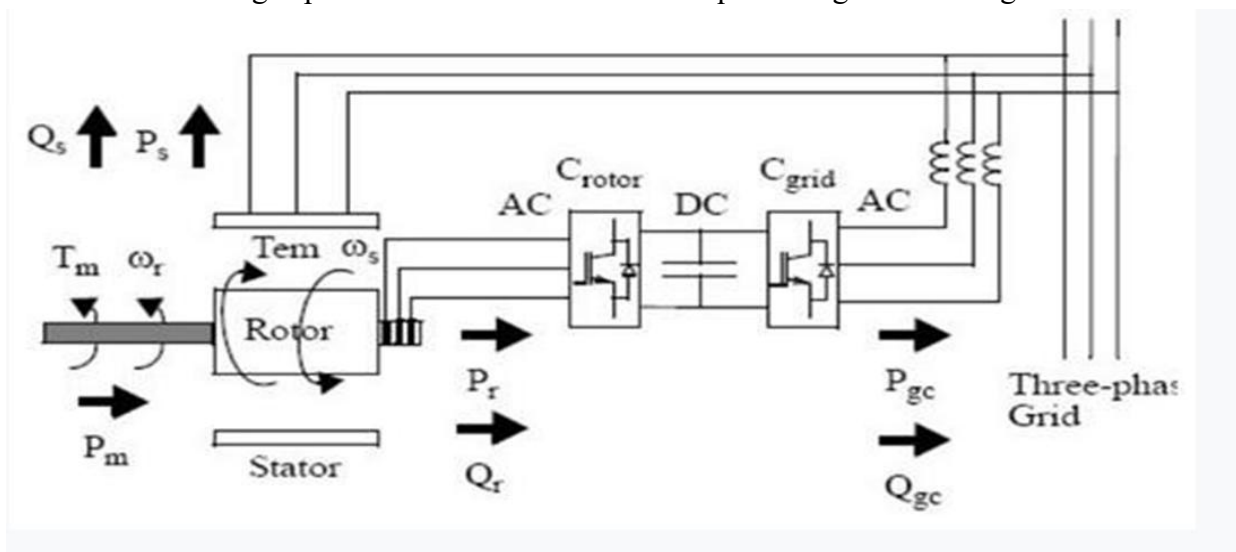

Figure 1: DFIG and its power flow

The stator is directly connected to the AC grid, while the wound rotor is fed from the Power Electronics Converter via slip rings to allow DFIG to operate at a variety of speeds in response to changing wind speed. Indeed, the basic concept is to interpose a frequency converter between the variable frequency induction generator and fixed frequency grid. To achieve full control of grid current, the DC-link voltage must be boosted to a level higher than the amplitude of grid line-to-line voltage. The slip power can flow in both directions, i.e. to the rotor from the supply and from supply to the rotor and hence the speed of the machine can be controlled from either rotor- or stator-side converter in both super and sub-synchronous speed ranges. As a result, the machine can be controlled as a generator or a motor in both super and sub-synchronous operating modes realizing four operating modes.

III WIND TURBINE MODELLING

The first wind turbines were based on a direct grid coupled synchronous generator with pitch controlled rotor blades to limit the mechanical power in high wind speeds. Therefore, the first modeling efforts were devoted to this wind turbine concept. The directly grid coupled synchronous generator was followed by a directly grid coupled asynchronous squirrel cage induction generator. To limit the power extracted from the wind at high wind speeds, either pitch control or stall control can be applied. Many papers on modeling of a wind turbine with a directly grid coupled squirrel cage induction generator can be found in the literature, both in combination with pitch control and with stall control of the mechanical power, and Nowadays, a more modern variable speed wind turbine with a doubly fed induction generator has replaced the conventional constant speed wind turbine with a directly grid coupled squirrel cage induction generator. As the power developed is proportional to the cube of the wind speed it is obviously important to locate any electricity generating turbines in areas of high mean annual wind speed, and the available wind resource is an important factor in determining where the wind farms are sited. Wind turbine rotor of A given rating is much larger in size than a hydro-turbine.

Rotor Equation

A wind turbine operates by extracting kinetic energy from the wind passing through its rotor. The power developed by a wind turbine is given by:

$$P = \frac{1}{2} C_p \rho V_w^3 A$$

Where

P power (W), C_p power coefficient, V_w Wind velocity (m/s),

A swept area of rotor disc (m²), ρ density of air (1.225 kg/m³).

The force extracted on the rotor is proportional to the square of the wind speed and so the wind turbine must be designed to withstand large forces during storms. Most of the modern designs are three-bladed horizontal-axis rotors as this gives a good value of peak C_p together with an aesthetically pleasing design. The power coefficient C_p is a measure of how much of energy in the wind is extracted by the turbine. It varies with the rotor design and the relative speed of the rotor

and wind to give a maximum practical value of approximately 0.4. As this needs knowledge of aerodynamics and the computations are rather complicated, numerical approximations have been developed.

$$C_p(\lambda, \beta) = 0.5176 \left(\frac{116}{\lambda} - 0.4\beta - 5 \right) e^{-\frac{21}{\lambda}} + 0.0068\lambda$$

$$\frac{1}{\lambda_i} = \frac{1}{\lambda + 0.08\beta} - \frac{0.035}{\beta^2 + 1}$$

Figure 2: Shows $C_p(\lambda, \mu)$ versus λ , characteristics for various values of λ . Using the actual values of the wind and rotor speed. The maximum value of C_p ($C_{pmax}=0.48$) is achieved for $\beta = 0^\circ$ and for $\lambda = 8:1$. This particular value of λ , is defined as the nominal value (λ_{nom}).

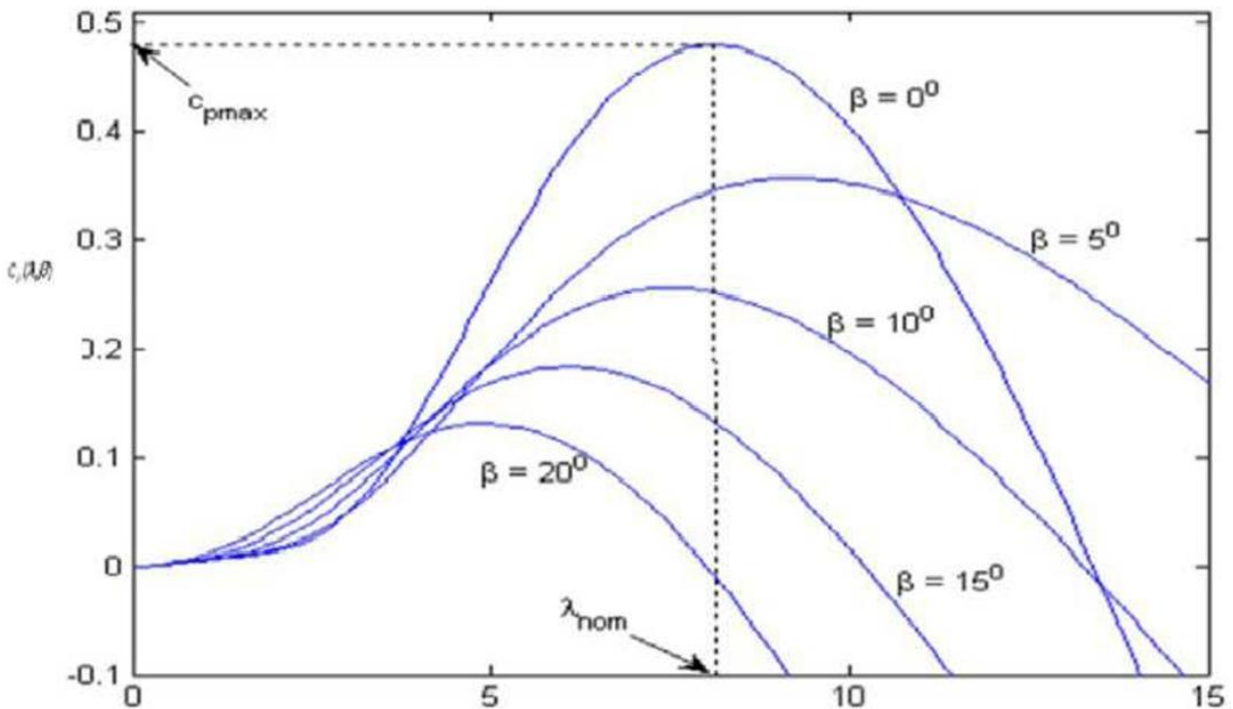

Figure 2: C_p vs λ characteristics

Performance coefficient C_p as a function of the tip speed ratio, with pitch angle λ as a parameter.

IV.AC/DC/AC CONVERTER

Where type and structure of the model is normally dictated by the particular requirements of the analysis, e.g. steady-state, fault studies, etc. This has been a popular approach with regard to DFIG modeling, where simulation of converters has been done based on expected response of controllers rather than actual modeling of Power Electronics devices. In fact, it is assumed that the converters are ideal and the DC-link voltage between them is constant. Consequently, depending on the converter control, a controllable voltage (current) source can be implemented to represent the operation of the rotor-side of the converter in the model. Physical model, on the other hand, models constituting elements of the system separately and also considers interrelationship among different elements within the system,

V.CONVERTER CONTROL SYSTEM

The back to back PWM converter has two converters, one is connected to rotor side and another is connected to grid side. Control by both converters has been discussed here. The rotor-side converter is used to control the wind turbine output power and the voltage measured at the grid terminals. The power is controlled in order to follow a pre-defined power-speed characteristic, named tracking characteristic.

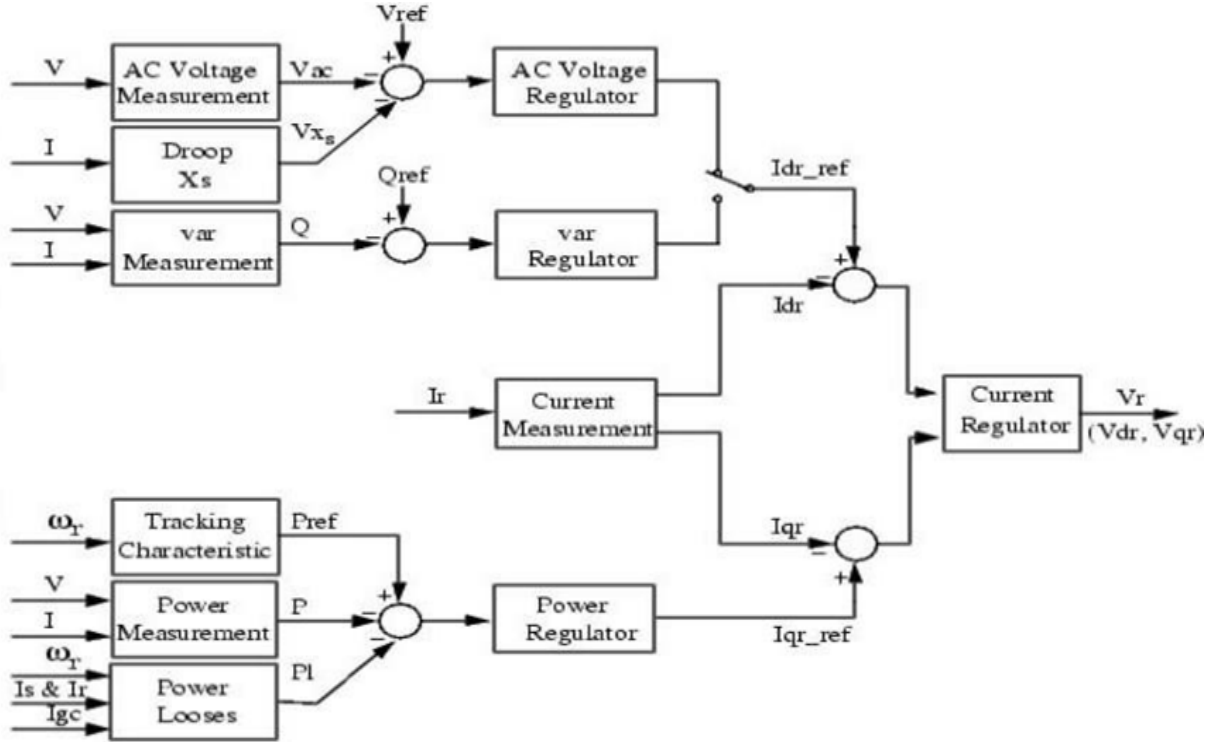

Figure 3: Rotor converter control block diagram

For the rotor-side controller the d-axis of the rotating reference frame used for d-q transformation is aligned with air-gap flux. The actual electrical output power, measured at the grid terminals of the wind turbine, is added to the total power losses (mechanical and electrical) and is compared with the reference power obtained from the tracking characteristic. A Proportional-Integral (PI) regulator is used to reduce the power error to zero. The output of this regulator is the reference rotor current I_{qr_ref} that must be injected in the rotor by converter C rotor. This is the current component that produces the electromagnetic torque T_{em} . The voltage at grid terminals is controlled by the reactive power generated or absorbed by the converter C rotor.

VI.GRID SIDE CONVERTER CONTROL SYSTEM.

The Grid side converter is used to regulate the voltage of the DC bus capacitor. For the grid-side controller the d- axis of the rotating reference frame used for d-q transformation is aligned with

the positive sequence of grid voltage.

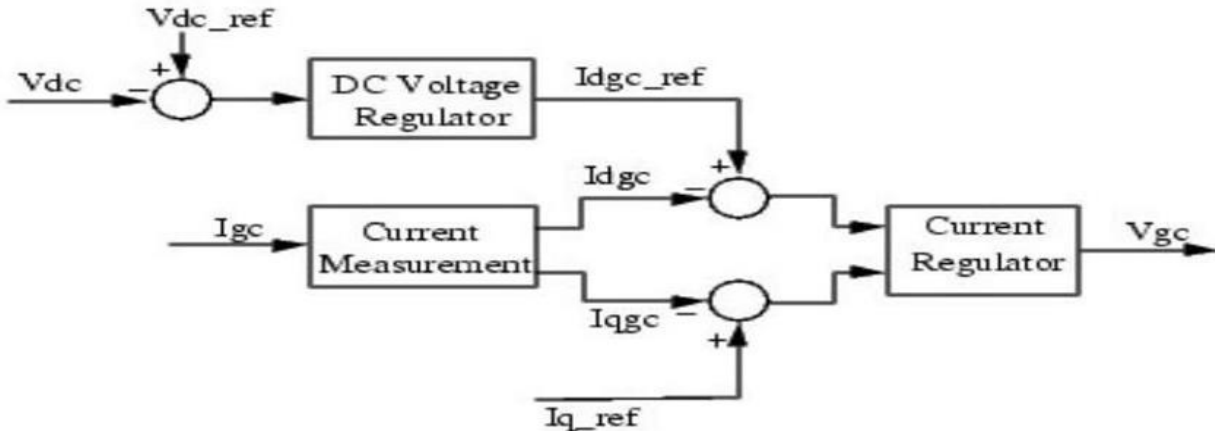

Figure 4. Grid side converter control

VII.SIMULATION DIAGRAM

This is the Simulink diagram for a doubly fed induction generator connected to grid side with wind turbine protection schemes involved for protection from single phase faults and ground faults. The system is connected to a 120 KV, 3 phase source which is connected to a 9MW wind farm (6 of 1.5 MW each) via. Step down transformers, fault protection and pi- transmission line.

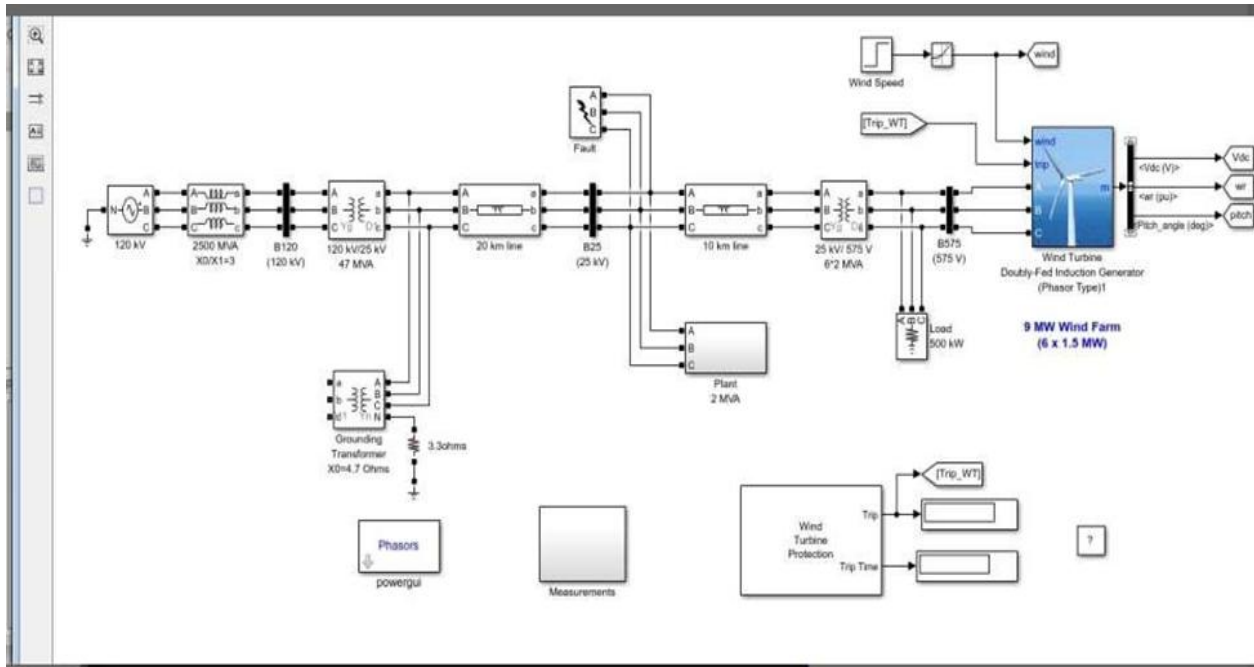

Figure 5: MATLAB model for the system

The wind-turbine model is a phasor model that allows transient stability type studies with long, simulation times. In this demo, the system is observed during 50 s.

VIII.SIMULATION RESULTS.

Turbine response to a change in wind speed "Wind Speed" step block specifying the wind speed. Initially, wind speed is set at 8 m/s, then at $t = 5s$, wind speed increases suddenly at 14 m/s. Start simulation and observe the signals on the "Wind Turbine" scope monitoring the wind turbine voltage, current, generated active and Reactive powers, DC bus voltage and turbine speed.

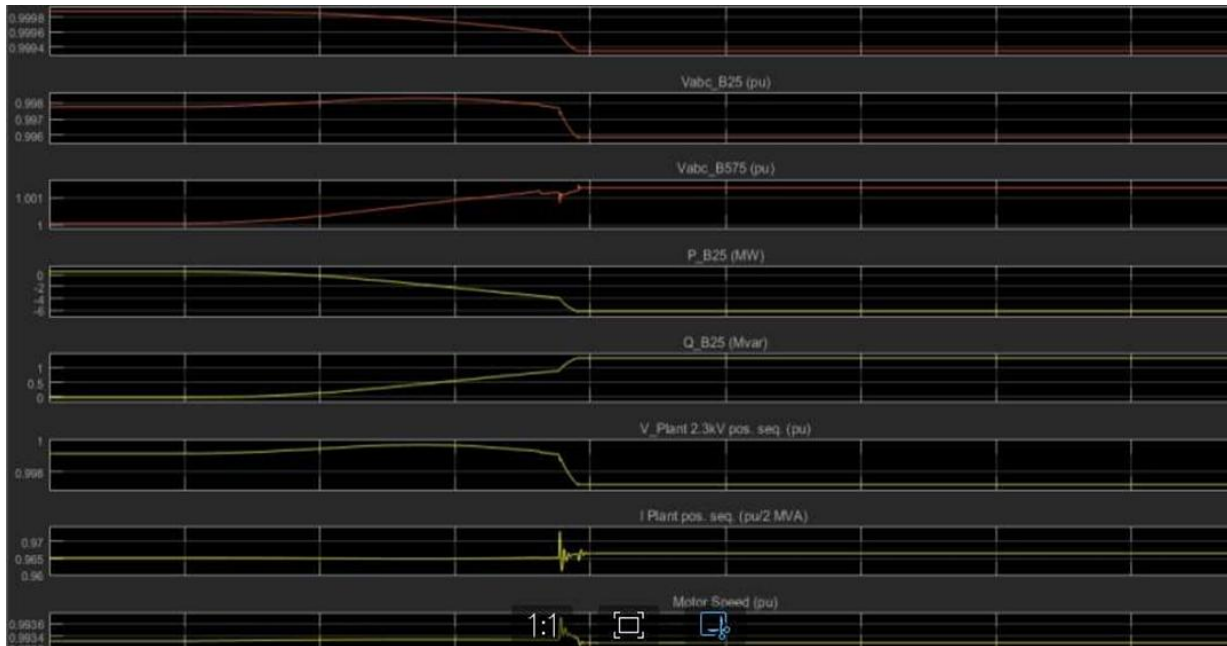

Figure 8: Grid voltage, current, active and reactive power

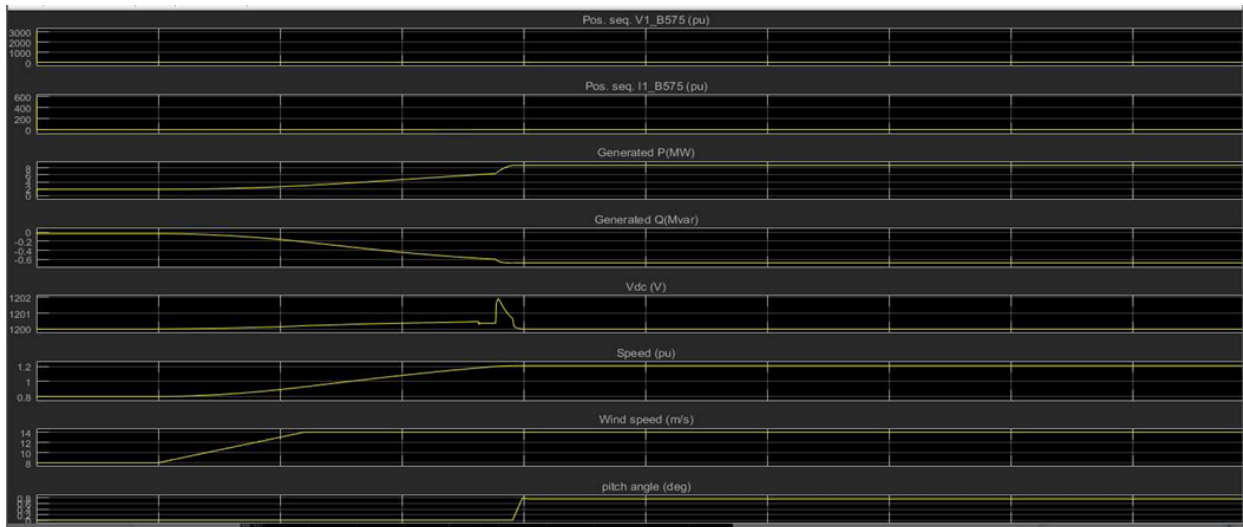

Figure 9: Wind turbine voltage, current, generated active and Reactive powers, DC bus voltage and turbine speed

IX.CONCLUSIONS

To obtain the best efficiency the DFIG system is used which is connected to grid side and has better control. The rotor side converter (RSC) usually provides active and reactive power control of the machine while the grid-side converter (GSC) keeps the voltage of the DC-link constant. So finally we simulated grid side and wind turbine side parameters and the corresponding results have been displayed. The faults can occur when wind speed decreases to a low value or it has persistent fluctuations. The DFIG is able to provide a considerable contribution to grid voltage support during short circuit periods. Doubly fed induction generator proved to be more reliable and stable system when connected to grid side with the proper converter control systems.

REFERENCES

- [1] Hector A. Pulgar-Painemal, Peter W. Sauer, “Doubly Fed Induction Machine in wind power generation”
- [2] Unpublished Paper, University of Illinois at Urbana-Champaign
- [3] John Fletcher and Jin Yang (2010). Introduction to the Doubly-Fed Induction Generator for Wind Power
- [4] Applications, University of Strathclyde, Glasgow, UK
- [5] Satish Choudhury, “Performance Analysis of Doubly-fed Induction Generator in Wind Energy Conversion
- [6] System” M.tech thesis, NIT Rourkela (2011)
- [7] Markus A. Poller, “Doubly-Fed Induction Machine Models for Stability Assessment of Wind Farms”
- [8] I. Erlich, M. Wilch and C. Feltes, “Reactive Power Generation by DFIG Based Wind Farms with AC Grid Connection”
- [9] Manfred Stiebler, “Wind Energy Systems for Electric Power Generation”
- [10] Shilpi Saini, “Review of Doubly Fed Induction Generator Used in Wind Power Generation”
- [11] Hans Øverseth Røstøen Tore M. Undeland Terje Gjengedal“ IEEE paper on doubly fed induction generator in a wind turbine.
- [12] Richard Gagnon, Gilbert Sybille, Serge Bernard, Daniel Paré, Silvano Casoria, Christian Larose “Modeling and Real- Time Simulation of a Doubly-Fed Induction Generator Driven by a Wind Turbine” Presented at the International Conference on Power Systems Transients (IPST‘05) in Montreal, Canada on June 19-23, 2005 Paper No. IPST05-162.
- [13] W.Leonhard, Control of Electrical Drives, 2nd ed. Berlin, Germany: Springer-Verlag, 1996.
- [14] S.Doradla,S. Chakrovorty,and K.Hole,”A new slip power recovery scheme with improved supply power factor” .IEEE, Trans.Fower Electron,vol,PE-3,no.2,pp.200-207.Apr,1988.
- [15] Ekanayake, J.B, Holdsworth, L, Wu, X., Jenkins, N. Dynamic modelling of Doubly Fed Induction generator wind turbines. IEEE Transaction on Power Systems, 2003, 2:803-809.
- [16] Mohm.Amer Abomahdi modelling and simulation of DFIG to grid connected wind power generation using matlab.IJEET
- [17] Abdelhakim, B., Ilhami, C., Korhan, K. & Ramazan, B. Modeling of a permanent magnet

- synchronous generator in a power wind generation system with an electrochemical energy storage. *Int. J. Smart Grid-Ijsmartgrid*. 2 (4), 197–202. <https://doi.org/10.20508/ijsmartgrid.v2i4.26.g25> (2018).
- [18] Rami, C. H., Naresh, R., Umapathi Reddy, K. & Sujatha, P. Control of DFIG based wind turbine with hybrid controllers. *Int. J. Renew. Energy Research-IJRER*. 10 (3), 1488–1500. <https://doi.org/10.20508/ijrer.v10i3.11010.g8028> (2020).
- [19] Hüseyin, C., Ahmet, D. & Yuksel, O. Investigation of dynamic behavior of double feed induction generator and permanent magnet synchronous generator wind turbines in failure conditions. *Int. J. Renew. Energy Res. -IJRER*. 11 (2), 721–729. <https://doi.org/10.20508/ijrer.v11i2.11837.g8193> (2021).
- [20] Bekhada, H. et al. Comparative study of pi, rst, sliding mode and fuzzy supervisory controllers for DFIG based wind energy conversion system. *Int. J. Renew. Energy research-ijrer*. 5 (4), 1174–1185. <https://doi.org/10.20508/ijrer.v5i4.2915.g6705> (2015).
- [21] Itouchene, H., Amrane, F. & Boudries, Z. Robust control of DFIG wind turbines in sub/super-synchronous operation using integral backstepping controller. *J. Renew. Energies*. 1 (1), 23–31. <https://doi.org/10.54966/jreen.v1i1.1170> (2024).
- [22] Larbi, D., Edgar, N. S. & Mohammed, B. Real-time neural sliding mode field-oriented control for a DFIG-based wind turbine under balanced and unbalanced grid conditions. *IET Renew. Power Gener.* 13 (4), 618–632. <https://doi.org/10.1049/iet-rpg.2018.5002> (2019).
- [23] Ahmed, S., Medhat, H. E., Ahmed, R. & Mahmoud, F. Performance evaluation of an optimized simplified nonlinear active disturbance rejection controller for rotor current control of DFIG-based wind energy system. *Clean. Eng. Technol.* 24, 100896. <https://doi.org/10.1016/j.clet.2025.100896> (2025).
- [24] Habib, B. Neuro-second order sliding mode field oriented command for DFIG based wind turbine. *Int. J. Smart Grid-Ijsmartgrid*. 2 (4), 209–217. <https://doi.org/10.20508/ijsmartgrid.v2i4.25.g27> (2018).
- [25] Habib, B. Application of Sta methods and modified Svm strategy in direct vector control system of Asg integrated to dual-rotor wind power: simulation studies. *Int. J. Smart Grid-Ijsmartgrid*. 5 (1), 63–73 (2021).
- [26] Mohammed, A., Ahmed, E., Tamou, N. & haitam, C. Comparative analysis of Adrc & Pi controllers used in wind turbine system driving a DFIG. *Int. J. Renew. Energy Research-ijrer*. 7 (4), 1816–1824 (2017).
- [27] Habib, B. Direct vector control for doubly fed induction generator-based wind turbine system using five-level Nsvm and two-level Nsvm technique. *Int. J. Smart Grid*. 3 (1), 25–32 (2019).
- [28] Habib, B. Application of seven-level neural space vector Pwm in direct vector control system of doubly fed induction generator for wind turbine. *Int. J. Smart Grid-Ijsmartgrid*. 3 (3), 163–171. <https://doi.org/10.20508/ijsmartgrid.v3i3.70.g62> (2019).
- [29] Abdeddaim, S., Betka, A., Drid, S. & Becherif, M. Implementation of Mrac controller of a DFIG based variable speed grid connected wind turbine. *Energy. Conv. Manag.* 79, 281–288. <https://doi.org/10.1016/j.enconman.2013.12.003> (2014).

- [30] Cárdenas, R., Peña, R., Proboste, J., Asher, G. & Clare, J. Mras observer for sensorless control of standalone doubly fed induction generators. *IEEE Trans. Energy Convers.* 20 (4), 710–718. <https://doi.org/10.1109/tec.2005.847965> (2005).
- [31] Elmouhi, N., Essadki, A. & Elaimani, H. Robust control of wind turbine based on doubly-fed induction generator optimized by genetic algorithm. *Int. J. Power Electron. Drive Syst.* 13 (2), 674–688. <https://doi.org/10.11591/ijpeds.v13.i2.pp674-688> (2022).
- [32] Samir, M., Mohamed, H., Nadir, K. & Selman, K. Neural network based field oriented control for doubly-fed induction generator. *Int. J. Smart Grid-Ijsmartgrid.* 2 (3), 183–187. <https://doi.org/10.20508/ijsmartgrid.v2i3.18.g18> (2018).